

CONCRETE BLOCK PAVING

Drainage of Concrete Block Paving



*A walk-over in cost, looks and
durability for Concrete Block Paving*



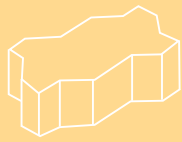
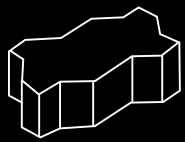

BACKGROUND

Concrete Block paving (cbp) differs from other forms of surfacing in that it comprises small segments and therefore is criss-crossed by a network of close spaced joints filled with sand. This means cbp is permeable and drainage of the surface and underlying layers is important. There is limited full scale testing world wide but from a study conducted by Dr Brian Shackel of the University of New South Wales, Australia, the following conclusions were drawn:-

- Between 30% to 35% of rainfall will penetrate newly laid, untrafficked, and unsealed block pavements.
- Increase in pavement crossfall will increase surface runoff. (Recommended min. slopes of 2%.)
- The permeability of the joints can be reduced by up to 50% with an application of a water based acrylic sealer. Similarly infiltration can be inhibited by using 10% of lime or 6% bentonite to the jointing sand.

Generally no attempt is made to seal the joints hence attention should be directed towards reducing the consequences of water infiltration, particularly during the early life of the pavement. In practice care must be taken to select bedding sands not susceptible to water or seal the base if it comprises unbound

granular materials or select base materials bound and waterproofed with cement, lime or bitumen.

The management of water runoff and infiltration becomes therefore a critical aspect that will affect the performance and integrity of the cbp. Good surface and subsoil drainage is essential for satisfactory pavement performance. Drainage needs to be considered during the design, specification construction phases of a project.

The following recommendations and detailing, although not new, but seldom practiced, are paramount for a trouble free and structurally sound cbp.

1 SURFACE DRAINAGE

Surface drainage should be designed and installed as thoroughly as for other pavements noting local site conditions such as:

- Climatic conditions, particularly rainfall.
- Ground water levels and seasonal influence ie. flood or tidal conditions.
- Soil profile.

Key detailing notes

- Min longitudinal fall of 1% and a crossfall of 2%.
- Paving should be set at a min. 5mm higher at drains, gutters and manhole inlets.

Surface drainage details

DETAIL A1 – DRAINS AND GUTTER

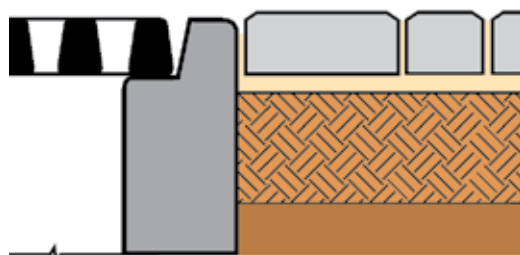

Pit or manhole

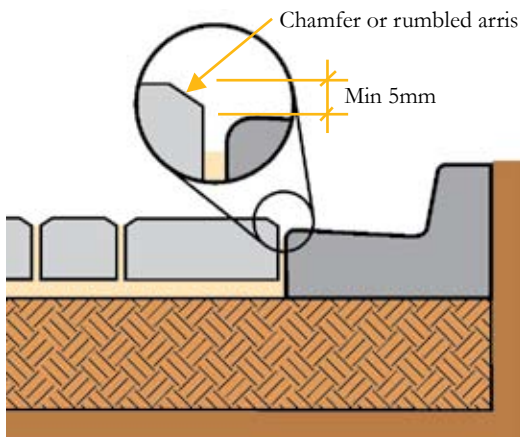

Kerb and gutter

DETAIL A2 – MANHOLE INLET

Min. 100mm Max. 200

Concrete infill, min 100mm thick 30 MPa

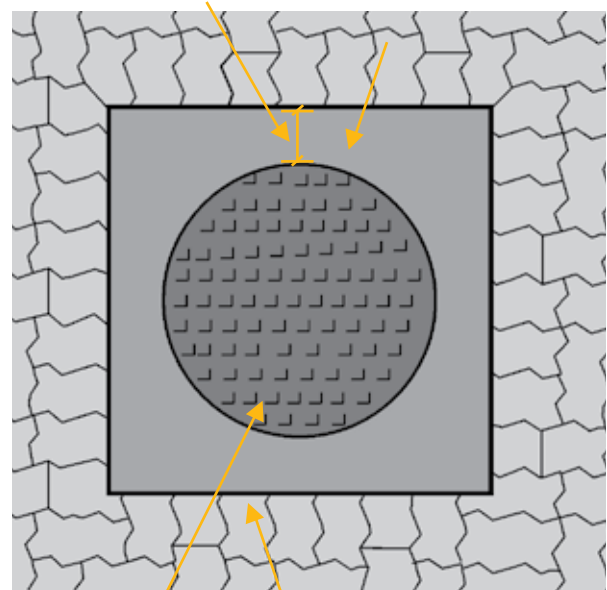

Manhole cover

Dimensions must be squared off and tied in with the paving pattern

- Special attention to compaction and possible stabilisation of backfill to manholes and inlet to prevent subsidence.

DETAIL A3 – INSITU CONCRETE DRAIN

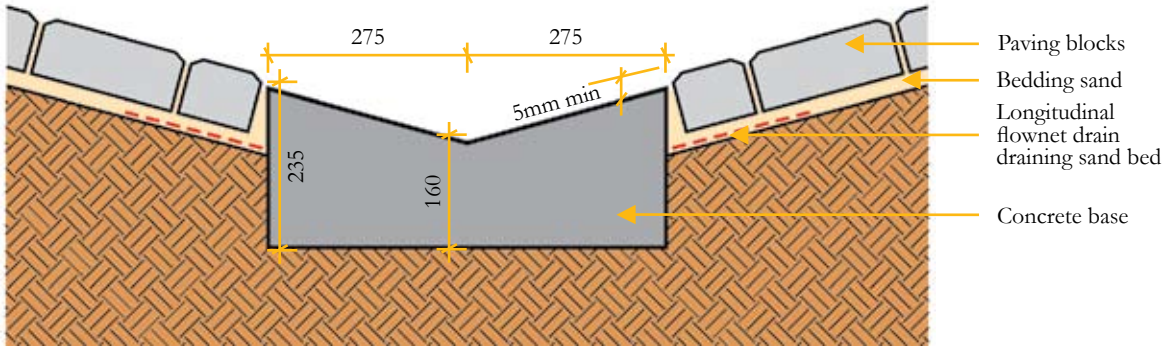

DETAIL A4 PRECAST CONCRETE DRAIN

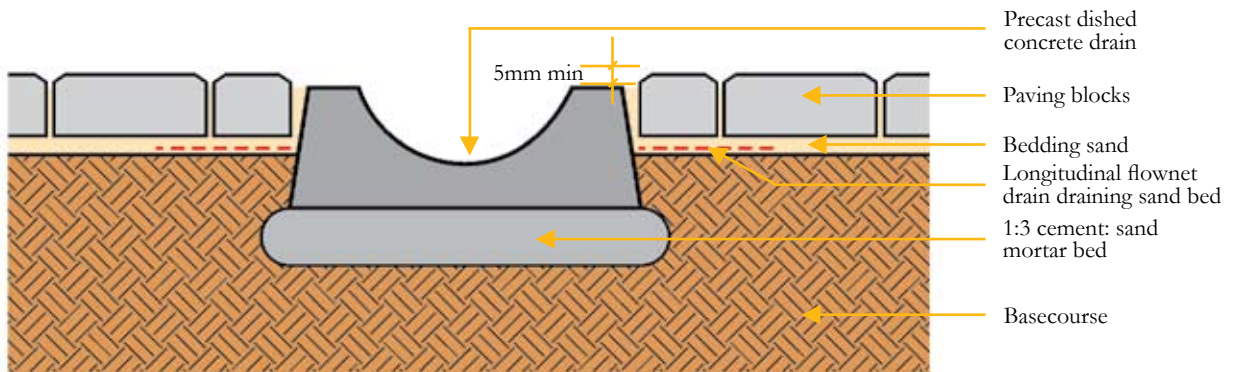

DETAIL A5 BLOCK PAVING DRAIN

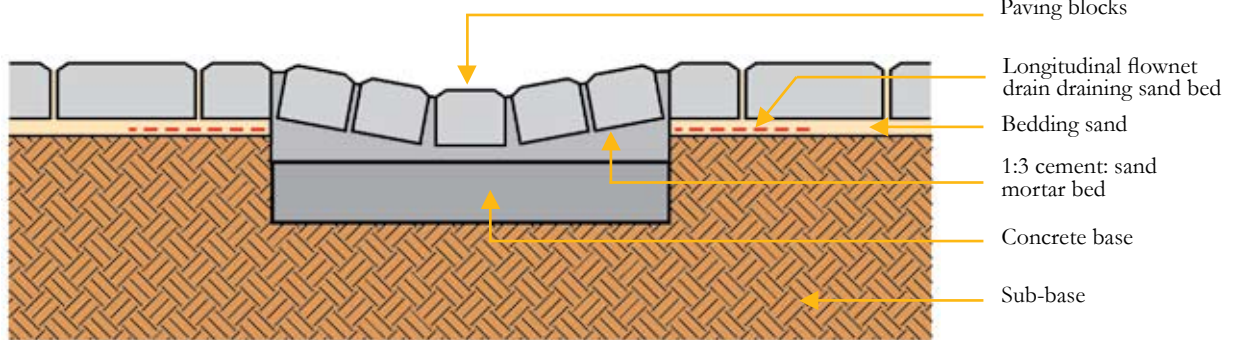

2 BEDDING LAYER DRAINAGE

The drainage of the bedding sand is crucial particularly where stabilised bases are used and up against kerbs, edge beams and manhole inlets. This aspect is often neglected and leads to a build up or "boxing" of water, which pumps under traffic washing out the jointing and bedding sand leading to progressive failure.

Select bedding sand not susceptible to water and to the correct grading.

NB: Bituminous seal should be considered for all unbound base material before placing bedding sand.

2.1 Bedding sand grading

(Nom sieve size mm)	% Passing
9,52	100
4,75	95-100
2,36	80-100
1,18	50-85
0,600	25-60
0,300	10-30
0,150	5-15
0,075	0-10

2.2 Jointing sand

- Sand should pass 1 18mm sieve and contain 10% - 50% of material passing a 0,075 sieve.

Sand bed drainage details

DETAIL B1 - STEEP SLOPES

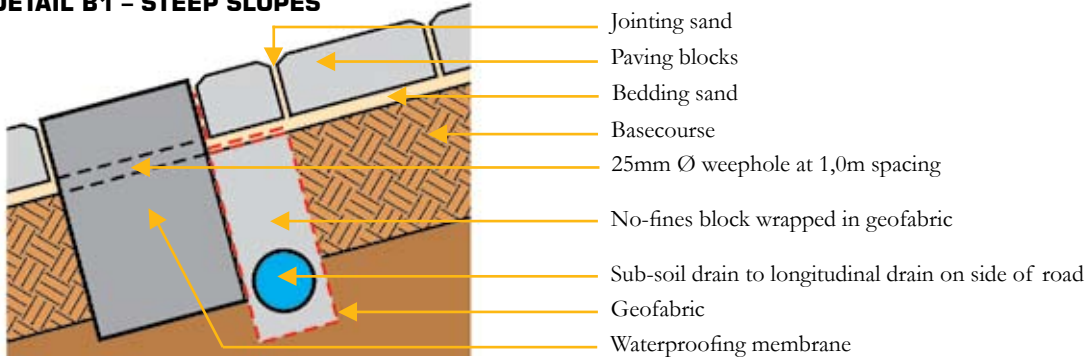

DETAIL B2 - INTO DRAINAGE PITS USING SUB SOIL DRAINS

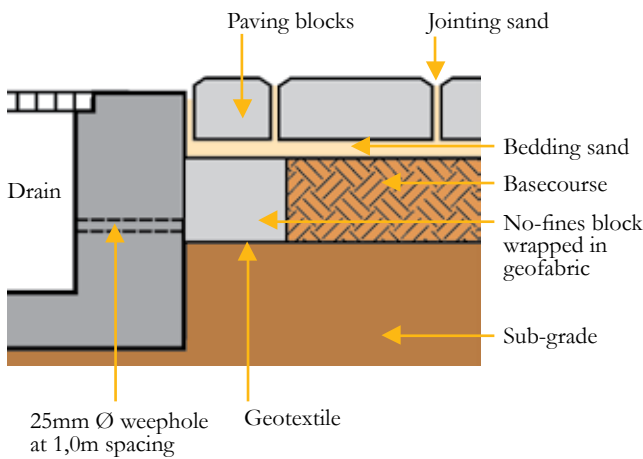

DETAILS B3 - INTO DRAINAGE PITS

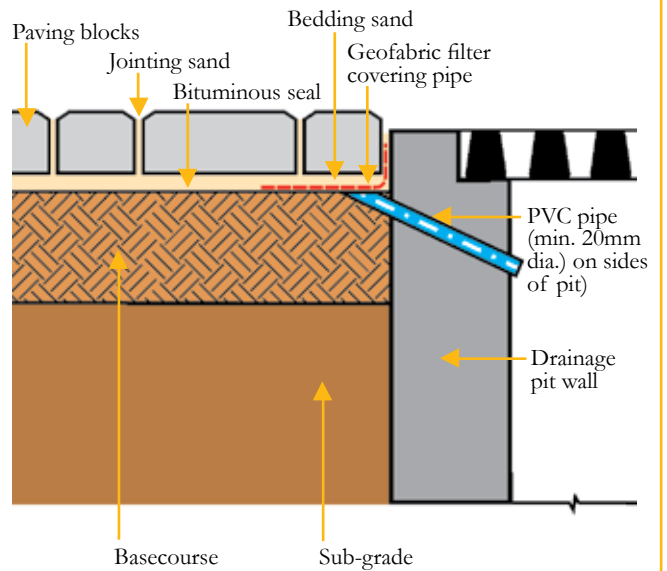

DETAILS B4 INTO SUBSOIL DRAIN

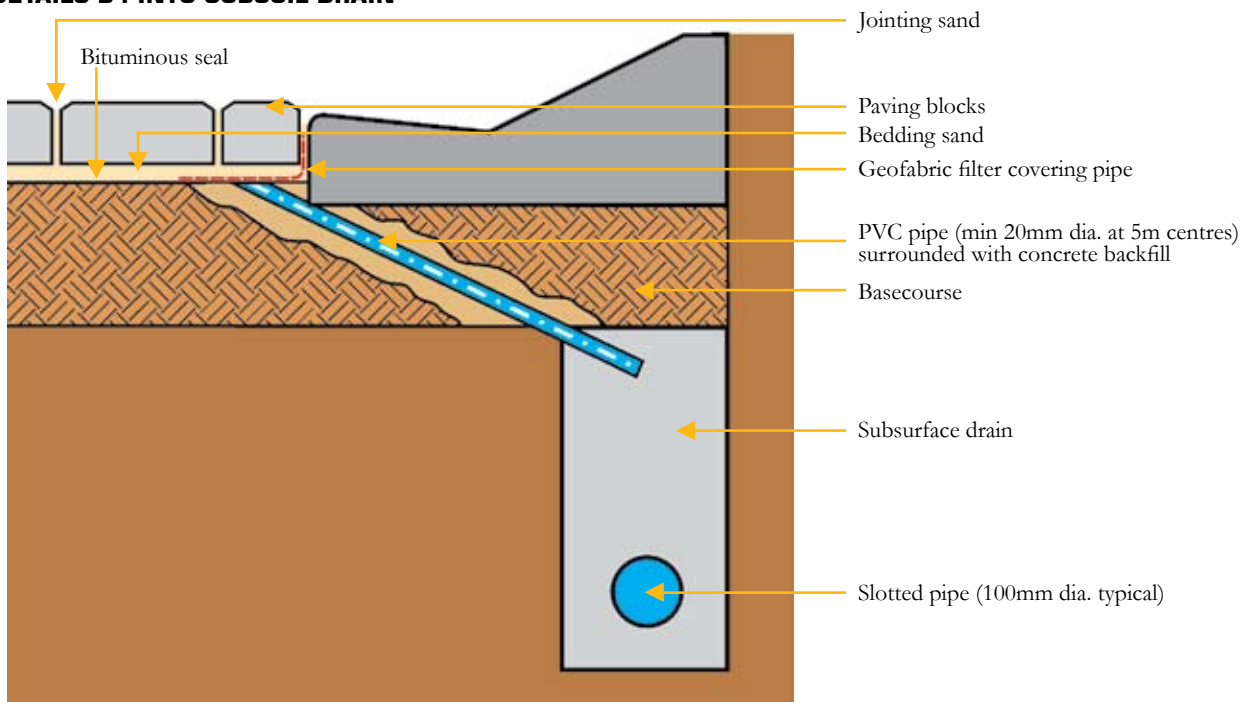

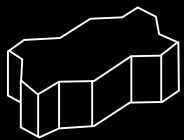

DETAIL B5 - PAVING OVER CONCRETE SLAB

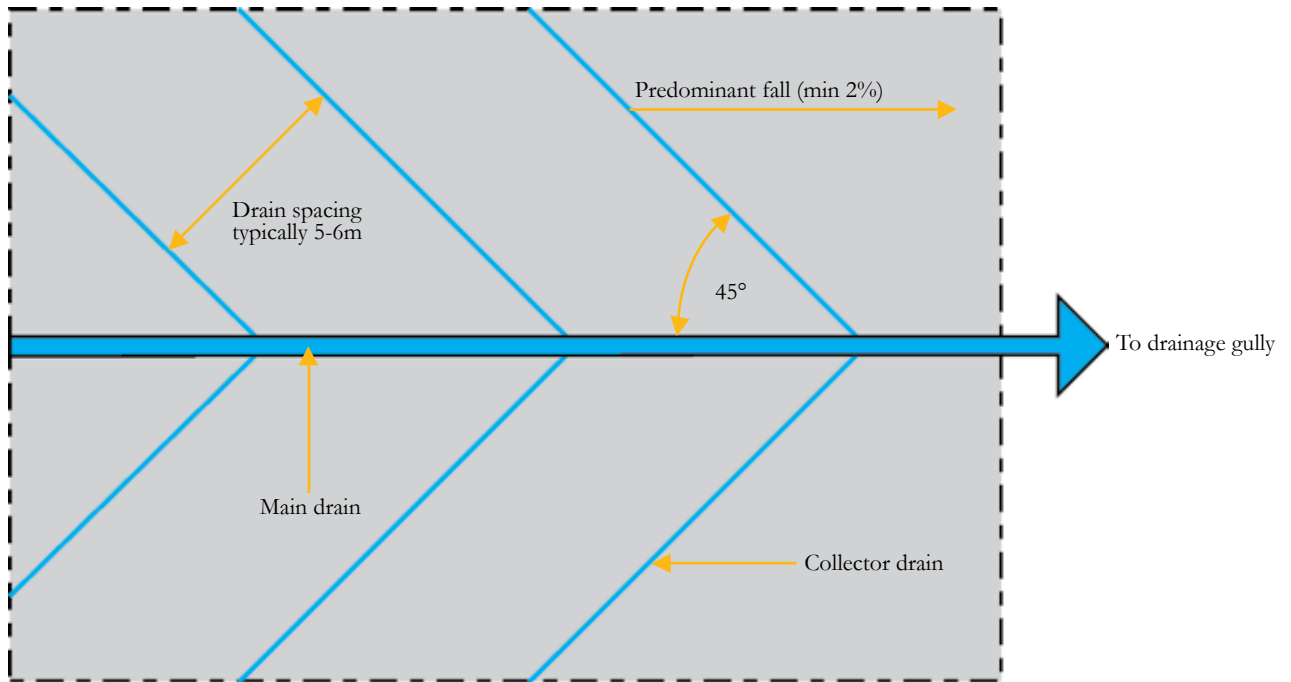

Plan view of fishbone drainage below paving

FLOWNET DRAINS

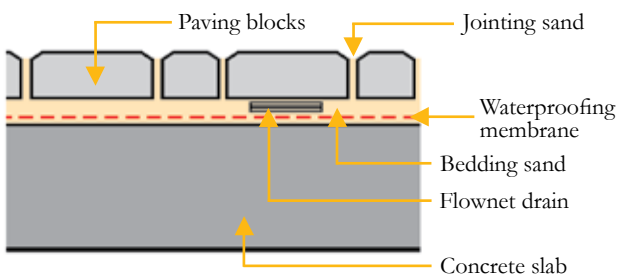
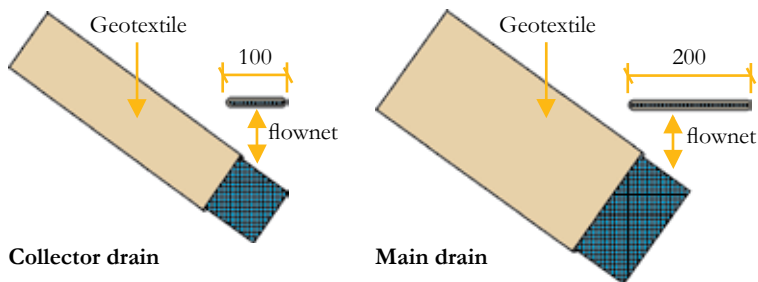

ALTERNATIVE DETAIL

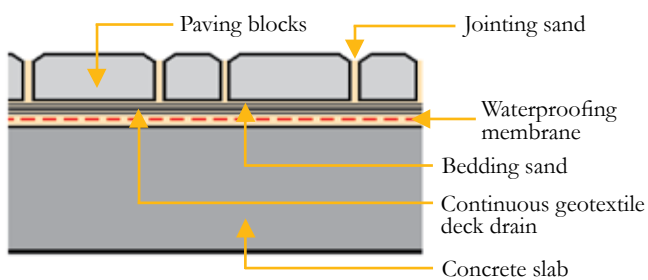

PAVING DIVISION MEMBERS (FEBRUARY 2009)

PRODUCER MEMBERS

<i>Bafokeng Concor Technicrete</i>	014 538 0818
<i>Baybrick</i>	035 792 5218
<i>Bosun Brick Midrand</i>	011 310 1176
<i>Brick & Concrete Industries (Namibia)</i>	0026 461 321 3009
<i>Brickcast Industries</i>	031 507 5525
<i>Brickbuild T/A Panda (Botswana)</i>	0026 724 42106
<i>Cape Brick</i>	021 511 2006
<i>C.E.L. Paving Products</i>	022 905 5998
<i>Cast Industries</i>	011 316 2375
<i>Columbia DBL</i>	021 905 1665
<i>Concor Technicrete</i>	011 495 2200
<i>Concor Technicrete P.E.</i>	041 372 2230
<i>Conframat</i>	016 987 3381
<i>Corobrik</i>	031 560 3911
<i>Deranco Paving</i>	041 933 2755
<i>Inca Concrete Products</i>	021 904 1620
<i>Inca Masonry Products</i>	043 745 1215
<i>Infrasat Gauteng</i>	011 652 0000
<i>KZN</i>	031 569 6900
<i>Kopano</i>	016 363 0340
<i>Mobicast Mossel Bay</i>	044 874 2268
<i>MVA Bricks</i>	012 386 0050
<i>Neat Contech</i>	046 624 3377
<i>Stanger Brick & Tile</i>	032 457 0237
<i>Stone Age Concepts</i>	011 740 0910
<i>Vanstone Precast</i>	012 541 2056
<i>Watson Concrete</i>	011 704 0910
<i>West End Bricks</i>	011 851 1828
<i>Zenzele Brix</i>	012 803 6884

ASSOCIATE MEMBERS

<i>Inca (Cape)</i>	021 904 1620
<i>Smartstone</i>	011 310 1161

CONTRACTOR MEMBERS

<i>Daron Construction</i>	034 955 1333
<i>Galaxy Paving</i>	011 815 1175
<i>Mondo Paving & Retaining Walls</i>	011 467 1111
<i>PYW Paving</i>	031 763 5771
<i>Roadstone Civil & Paving</i>	011 683 7080
<i>S A Paving Gauteng</i>	031 705 5123
<i>The Paving Creations</i>	031 765 4083
<i>Vesles Civils</i>	012 662 3030/1
<i>Valcal International</i>	011 867 2471